

Kit Contents		
Description	Part No	Pcs
Front fork	FGRT 307	1
Screw	01046-38	4
Screw	00382-52	2
Spring	08444-12	1
Spring	08444-14	1
Fender bracket front RH	21665-25	1
Fender bracket front LH	21665-26	1
Fender bracket back RH	21665-27	1
Fender bracket back LH	21665-28	1
Sticker set Öhlins		1
Owner's Manual	07282-07	1

👁 Note!

Please note that there can be small differences between your product and the images in these instructions.

👁 Note!

Please note that during storage and transport, especially at high ambient temperature, some of the oil and grease used for assembly may leak and stain the packaging. This will not cause damage to the product, wipe off the excessive oil or grease with a cloth.

👁 Note!

Before you install this product, check the kit contents. If anything is missing, please contact an Öhlins dealer.

⚠ Warning!

Before you install this product, read the Öhlins Owner's manual. This product is an important part of the vehicle and the vehicle stability.

Front Fork for Harley-Davidson CVO Road Glide

FGRT 307

Mounting Instructions



ÖHLINS

MOUNTING INSTRUCTIONS

⚠ Warning!

We strongly recommend to let an Öhlins dealer install this product.

⚠ Warning!

If you work with a lifted vehicle, make sure that it is safely supported to prevent it from tipping over.

👁 Note!

When you work with this product, see the vehicle service manual for vehicle specific procedures and important data.

👁 Note!

Before you install this product clean the vehicle.

1

Put the motorcycle on a work stand so that the front wheel barely touches the ground.

2

Remove the front fender, brake calipers, speed sensor and front wheel. Refer to the vehicle service manual for correct procedure.

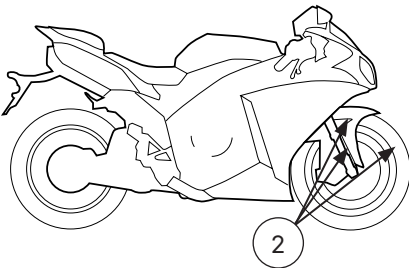

3

Loosen the bolts on the upper and lower triple clamps.

4

Remove the front fork legs from the motorcycle.

5

Install the supplied fender brackets to the fork legs. Apply Loctite 2400 or similar to the screws and tighten to 4 Nm.

6

Install the front fork legs in the triple clamps at front fork leg position according to setup data. Turn the handle bars fully from side to

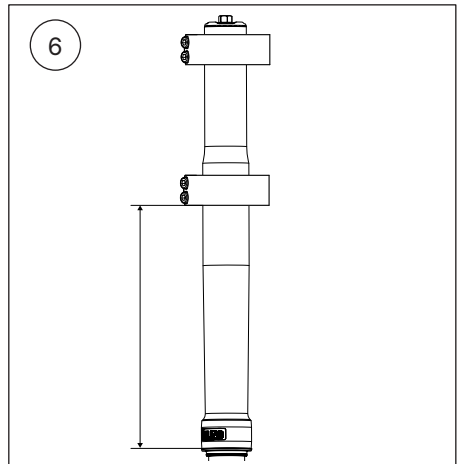
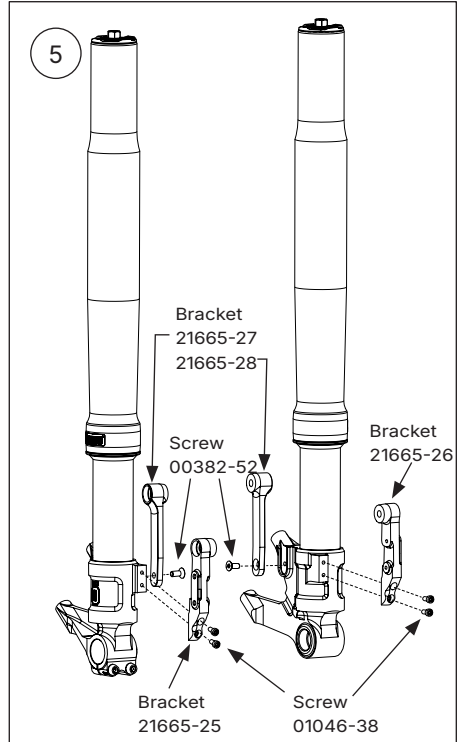

side to make sure that nothing restricts the movement, and that the throttle cable and the wire harness run in smooth bends.

MOUNTING INSTRUCTIONS

7

Tighten the upper triple clam bolts and the lower triple clamp bolts according to the vehicle's service manual.

8

Install the front wheel, front fender, wheel speed sensor and the brake calipers. Do not tighten yet. If needed, adjust the position of the rubber bushing so the speed sensor cable is positioned above the brake caliper.

⚠ Warning!

Ensure that the speed sensor cable does not touch the wheel at full lock turns and when the suspension is fully compressed or extended.

9

Put the vehicle on the ground, apply the front brake and compress the front fork distinctly 3-4 times. This will position the front fork legs parallel.

10

Tighten the front axle in the left fork bottom according to the vehicle's service manual. Tighten the right fork bottom's front axle pinch bolts at 19 Nm and then tighten the brake caliper bolts according to the vehicle's service manual.

11

Close the compression and rebound adjusters.

12

Compress the front fork as much as possible several times to release air trapped inside the damping systems. Ensure that there is damping on the full stroke.

13

Set the compression and rebound adjusters, see setup data.

👉 Caution!

Make sure that you tighten all screws to the correct torque and that nothing fouls or restricts movement of the front fork when the suspension is fully compressed or extended.

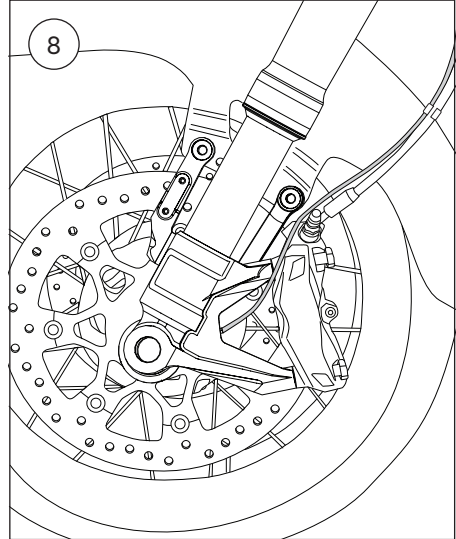

ADJUSTMENTS

⚠ Warning!

Before you ride/drive, always make sure that the setup is according to the recommended setup data. Read about adjustments and setting up in the Öhlins Owner's Manual before you make any adjustments. Contact an Öhlins dealer if you have any questions about set up.

Spring
preload
adjuster

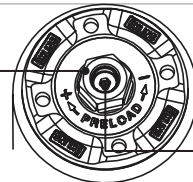

Compression/
Rebound
adjuster

SETUP DATA

Compression adjustment	12	clicks
Rebound adjustment	12	clicks
Suspension fluid level	170	mm
Front fork leg position	233	mm
Suspension fluid part number	01309-01	
Main spring rate standard	13	N/mm
Main spring preload standard	7	turns

MAIN SPRING GUIDE

Make sure you choose the correct main spring for your rider weight, driving style and preferences. Below you find a general recommendation of main spring rate for your weight. Contact an authorized Öhlins service center for advice.

👁 Note!

08423-xx main springs are packed in pairs.
08444-xx main springs are packed in pcs.

Rider weight [kg]	60	70	80	90	100	110	120	130
Spring rate [N/mm]	12	12	13	13	13	14	14	14
Preload [turns]	8	10	7	8	10	7	8	9
Part number (pair)	08423-12	08423-12	08423-13	08423-13	08423-13	08423-14	08423-14	08423-14
Part number (single)	08444-12	08444-12	08444-13	08444-13	08444-13	08444-14	08444-14	08444-14

SUSPENSION FLUID LEVEL -

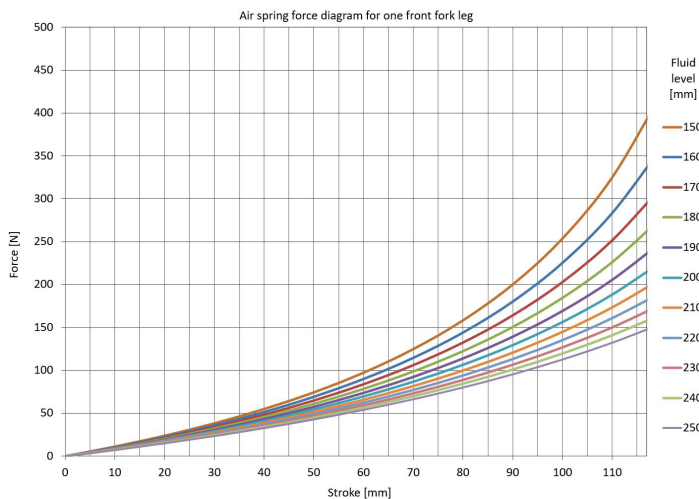

Öhlins products are subject to continuous improvement and development, therefore, although these instructions include the most up-to-date information available at the time of printing, minor updates may occur.

To find the latest information contact an Öhlins distributor. Please contact Öhlins if you have any questions regarding the contents in this document.

Part no. MI_FGRT307_2
Issued 2025-10-22

© Öhlins Group AB. All rights reserved. Any reprinting or unauthorized use without the written permission of Öhlins Group AB is prohibited.

Öhlins Group AB
Box 722
S-194 27 Upplands Väsby, Sweden
Phone +46 8 590 025 00
fax +46 8 590 025 80

